

# Avseal® 2961



For installation information please refer to the tooling overview and manuals on our website [www.avdel-global.com](http://www.avdel-global.com).  
 Pour les conditions de pose, merci de vous référer à la description de l'outil et aux manuels disponibles sur notre site Web.  
 Angaben zur Verarbeitung entnehmen Sie bitte der Geräteübersicht und den Betriebsanleitungen auf unserer Website.  
 Per informazioni sull'installazione preghiamo consultare i manuali e la panoramica degli attrezzi sul nostro sito web.  
 Para ver información sobre máquinas de colocación, consulte nuestra página web, apartados visión general de máquinas y manuales.

English	Français	Deutsch	Italiano	Español
High pressure series	Version haute pression	Hochdruckversion	Versione alta pressione	Versión altas presiones
Sleeve: Aluminium Alloy*	Douille: Alliage d'aluminium*	Hülse: Aluminium*	Bussola: Lega di alluminio*	Cuerpo: Aluminio*
Stem: Carbon steel** hardened and tempered Zinc plated, colourless passivation with top seal	Tige: Acier bas carbone** renforcé et trempé Zingué, passivation incolore avec „top seal“	Dorn: Stahl** gehärtet und vergütet Verzinkt, klar passiviert mit Versiegelung	Gambo: Acciaio a basso tenore di carbonio** temprato Zincato, passivazione chiara con sigillante	Vástago: Acero bajo en carbono** endurecido y tratado Zincado, pasivado claro con sellante



\*: BS1473/4/5 - 6061/AA6061 EN 573-3 AlMg1SiCu Werkstoff 3.3211

\*\* : BS 3111 type 10 DIN 1654 35B2

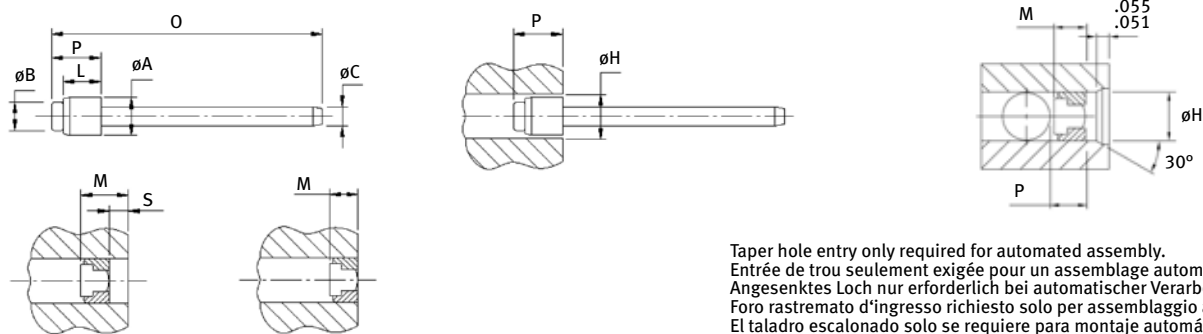

Taper hole entry only required for automated assembly.  
 Entrée de trou seulement exigée pour un assemblage automatisé.  
 Angesenktes Loch nur erforderlich bei automatischer Verarbeitung.  
 Foro rastreado d'ingresso richiesto solo per assemblaggio automatico.  
 El taladro escalonado solo se requiere para montaje automático.

ø	O max.	øB ref.	øA max.	L max.	øC ref.	øH			P <sup>1)</sup> req.	M <sup>1)</sup>		Part No/ref
						min.	max.	rec.		min.	max.	
4.0 mm	1.630	.118	.154	.161	.075	.154	.169	.161	.256	.111	.170	02961-00405
5.0 mm	1.661	.150	.193	.197	.087	.197	.212	.197	.281	.156	.224	02961-00506
6.0 mm	1.972	.177	.232	.236	.102	.236	.251	.236	.336	.170	.343	02961-00607
7.0 mm	2.012	.213	.268	.272	.118	.276	.291	.276	.385	.203	.361	02961-00708
8.0 mm	2.043	.240	.307	.311	.142	.308	.330	.315	.435	.283	.370	02961-00810
9.0 mm	2.087	.272	.346	.335	.154	.347	.385	.354	.500	.301	.387	02961-00911
10.0 mm	2.102	.308	.386	.394	.173	.386	.425	.394	.551	.346	.511	02961-01012
11.0 mm	2.421	.339	.425	.469	.189	.426	.464	.433	.593	TBA <sup>2)</sup>	.551	02961-01113
12.0 mm	2.472	.370	.465	.453	.209	.465	.503	.472	.620	.420	.572	02961-01215

all dimensions in inches / en pouces / alle Maße in Zoll / in pollici / en pulgadas

1) Values for use with a flat nose tip (except for 4.0 & 5.0 mm where only stepped nosetips are available):

- Add „S“ = .079 / .315 to „P“ and „M“ values when a 2 mm / 8 mm extended nose tip is used

Valeurs pour l'utilisation de nez de pose plat (à l'exception des diamètres 4,0 et 5,0mm ou seulement des nez étagés sont disponibles)

- Ajouter „S“ = .079 / .315 aux valeurs „P“ et „M“ quand un nez de pose étagé de 2mm/8mm est utilisé

Werte für Verwendung eines flachen Mundstückes (außer für 4,0 & 5,0 mm wo nur abgesetzte Mundstücke verfügbar sind):

- Addieren Sie „S“ = .079 bzw .315 zu den Werten für „P“ und „M“ wenn ein 2 mm bzw. 8 mm Mundstück verwendet wird

Valori per uso con nasello a filo (eccetto per 4 & 5 mm. dove sono disponibili solo i naselli lunghi):

- Aggiungere „S“ = .079 / .315 ai valori „P“ e „M“ quando sono usati naselli lunghi da 2 mm / 8 mm

Valores con sufridera plana (excepto para diámetros 4 y 5 mm que solo están disponibles para sufrideras de pitón):

- Añadir „S“ = .079 / .315 a „P“ y „M“ si se utiliza sufrideras de pitón 2 mm y 8 mm

2) to be announced / doit être annoncé / wird noch bekanntgegeben / da comunicare / se comunicará próximamente



An Acument™ Global Technologies Company

[www.avdel-global.com](http://www.avdel-global.com)

© 2007 Acument Intellectual Properties, LLC

Avseal® is a trademark of Avdel UK Limited

06.2009

Data shown is subject to change without prior notice as a result of continuous product development and improvement policy.  
 Your local Avdel representative is at your disposal should you need to confirm latest information.