

Avseal® 2964

For installation information please refer to the tooling overview and manuals on our website www.avdel-global.com.
 Pour les conditions de pose, merci de vous référer à la description de l'outil et aux manuels disponibles sur notre site Web.
 Angaben zur Verarbeitung entnehmen Sie bitte der Geräteübersicht und den Betriebsanleitungen auf unserer Website.
 Per informazioni sull'installazione preghiamo consultare i manuali e la panoramica degli attrezzi sul nostro sito web.
 Para ver información sobre máquinas de colocación, consulte nuestra página web, apartados visión general de máquinas y manuales.



English	Français	Deutsch	Italiano	Español
Low pressure series	Version basse pression	Niedrigdruckversion	Versione bassa pressione	Versión bajas presiones
Sleeve: Aluminium Alloy*	Douille: Alliage d'aluminium*	Hülse: Aluminium*	Bussola: Lega di alluminio*	Cuerpo: Aluminio*
Stem: Carbon steel** hardened and tempered Zinc plated, colourless passivation with top seal	Tige: Acier bas carbone** renforcé et trempé Zingué, passivation incolore avec „top seal“	Dorn: Stahl** gehärtet und vergütet Verzinkt, klar passiviert mit Versiegelung	Gambo: Acciaio a basso tenore di carbonio** temprato Zincato, passivazione chiara con sigillante	Vástago: Acero bajo en carbono** endurecido y tratado Zincado, pasivado claro con sellante



*: BS1473/4/5 - 6061/AA6061 DIN 1725 AlSiCu Werkstoff 3.3211

** : BS 3111 type 10 DIN 1654 35B2

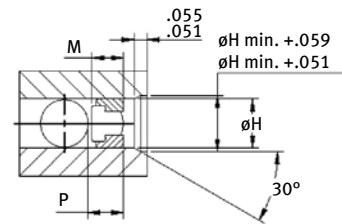
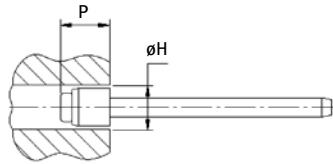
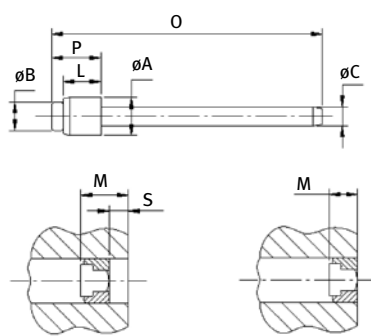

Taper hole entry only required for automated assembly.
 Entrée de trou seulement exigée pour un assemblage automatisé.
 Angesenktes Loch nur erforderlich bei automatischer Verarbeitung.
 Foro rastremato d'ingresso richiesto solo per assemblaggio automatico.
 El taladro escalonado solo se requiere para montaje automático.

ø	O nom.	øB ref.	øA nom.	L nom.	øC ref.	øH			P ¹⁾ req.	M ¹⁾		Part No/ref
						min.	max.	rec.		min.	max.	
8.0 mm	1.957	.236	.303	.295	.140	.315	.320	.315	.457	.296	.374	02910-10790
9.0 mm	1.988	.240	.343	.319	.142	.347	.370	.354	.461	.284	.416	02964-00911
10.0 mm	2.020	.276	.382	.358	.154	.386	.409	.394	.514	.347	.451	02964-01012
11.0 mm	2.051	.307	.421	.366	.173	.426	.448	.433	.538	.371	.476	02964-01113
12.0 mm	2.051	.307	.461	.358	.173	.465	.488	.472	.529	.373	.470	02964-01215
13.0 mm	2.394	.339	.500	.386	.189	.504	.527	.512	.580	.396	.492	02964-01315
14.0 mm	2.421	.370	.539	.417	.209	.544	.566	.551	.616	.461	.546	02964-01415
15.0 mm	2.469	.402	.579	.449	.220	.583	.606	.591	.667	TBA ²⁾		02964-01520
16.0 mm	2.500	.433	.618	.476	.236	.623	.645	.630	.710	.547	.629	02964-01620

all dimensions in inches / en pouces / alle Maße in Zoll / in pollici / en pulgadas

1) Values for use with a flat nose tip (except for 4,0 & 5,0 mm where only stepped nosetips are available):

- Add „S“ = .079 / .315 to „P“ and „M“ values when a 2 mm / 8 mm extended nose tip is used

Valeurs pour l'utilisation de nez de pose plat (à l'exception des diamètres 4,0 et 5,0mm où seulement des nez étagés sont disponibles)

- Ajouter „S“ = .079 / .315 aux valeurs „P“ et „M“ quand un nez de pose étagé de 2mm/8mm est utilisé

Werte für Verwendung eines flachen Mundstückes (außer für 4,0 & 5,0 mm wo nur abgesetzte Mundstücke verfügbar sind):

- Addieren Sie „S“ = .079 bzw. .315 zu den Werten für „P“ und „M“ wenn ein 2 mm bzw. 8 mm Mundstück verwendet wird

Valori per uso con nasello a filo (eccetto per 4 & 5 mm. dove sono disponibili solo i naselli lunghi):

- Aggiungere „S“ = .079 / .315 ai valori „P“ e „M“ quando sono usati naselli lunghi da 2 mm / 8 mm

Valores con sufridera plana (excepto para diámetros 4 y 5 mm que solo están disponibles para sufrideras de pitón):

- Añadir „S“ = .079 / .315 a „P“ y „M“ si se utiliza sufrideras de pitón 2 mm y 8 mm

2) To be announced/ doit être annoncé / wird noch bekanntgegeben / da comunicare / se comunicará próximamente



An Acument™ Global Technologies Company

www.avdel-global.com

© 2007 Acument Intellectual Properties, LLC

Avseal® is a trademark of Avdel UK Limited

04.2008

Data shown is subject to change without prior notice as a result of continuous product development and improvement policy.
 Your local Avdel representative is at your disposal should you need to confirm latest information.