

Briv[®], Chobert[®] & Grovit[®] Nose Equipment

Ensembles de nez / Mundstücke / Equipaggiamento / Equipos de colocación

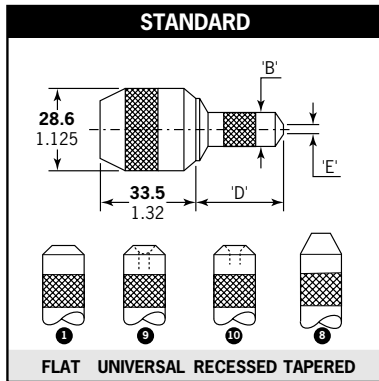

Applications with no or little access restrictions.
Pour applications ne présentant que peu ou pas de contraintes d'accès.

Für alle gut zugänglichen Nietpunkte.
Adatta per applicazioni senza restrizioni di accesso o con restrizioni di accesso limitate.
Apta para aquellas aplicaciones sin ninguna o pocas restricciones de acceso.

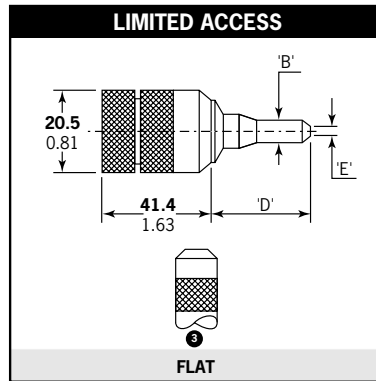

Allows access into very restrictive applications.
Permet d'accéder à des applications à accès très limité.

Für eng an den Bauteilseiten anliegende Nietpunkte.
Consente l'accesso ad applicazioni con serie restrizioni di accesso.
Permite el acceso en aplicaciones de acceso extremadamente limitado.

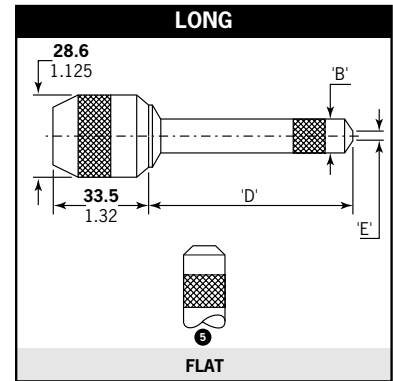

Allows more penetration into applications.
Permet une pénétration supérieure dans les applications sans autres contraintes d'accès.

Für tiefsitzende und eng an den Bauteilseiten anliegende Nietpunkte.
Consente una penetrazione maggiore nell'applicazione senza altre restrizioni di accesso.
Permite una mayor profundidad de acceso en aquellas aplicaciones sin restricción de acceso en anchura.

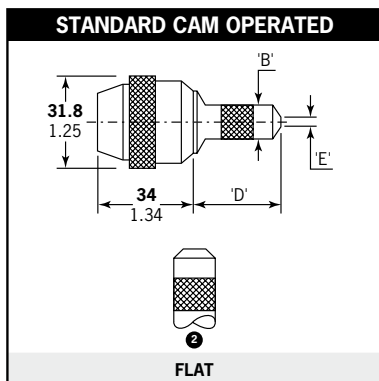

Nose equipment with addition of a twist cam to ease and speed up the nose jaw opening thus the pod reloading procedure.

Ensembles de nez avec, en plus, une came facilitant et accélérant l'ouverture du nez de pose, et donc le rechargement en fixations.

Zum leichteren Magazinieren haben diese Mundstücke durch einen Drehring zu öffnende Mundstückschnäbel.

Equipaggiamento con l'aggiunta di una camma per facilitare e rendere più veloce l'apertura della testata e pertanto la procedura di ricarica dell'astuccio portarivetti.

Boquillas que incorporan una leva para facilitar y hacer más rápida la apertura de la boquilla y el procedimiento de carga.

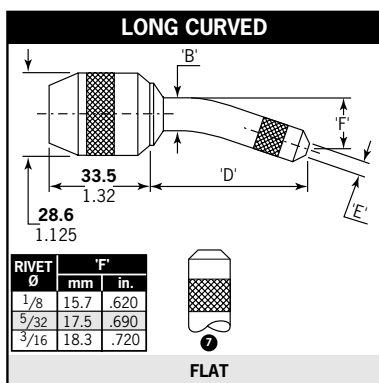
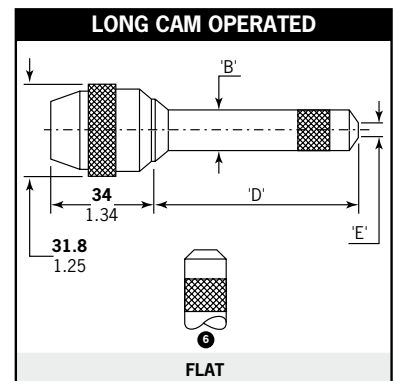
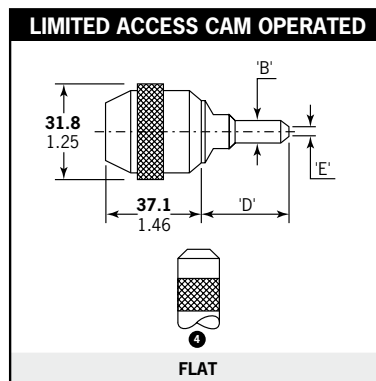

Allows more penetration into applications.
Permet une pénétration supérieure dans les applications à accès limité.
Für tiefsitzende und eng an den Bauteilseiten anliegende Nietpunkte.
Consente una penetrazione maggiore nelle applicazioni con restrizioni di accesso.
Permite una mayor penetración en las aplicaciones con acceso limitado.

Type

- 1 - 7 Flat / Plat / Flach / Piatta / Plana
- 8 Tapered / Biseauté / Spitz / A punta / Conica
- 9 Universal / Universel / Für erhöhte Klammerkraft / Universale / concava
- 10 Recessed / En retrait / Spezial / Incassata / Apriete



www.avdel-global.com

Briv[®], Chobert[®] and Grovit[®] are trademarks of Avdel UK Limited

© 2010 Infastech

Data shown is subject to change without prior notice as a result of continuous product development and improvement policy.
Your local Avdel representative is at your disposal should you need to confirm latest information.

10.2009, page 1/2

Briv[®], Chobert[®] & Grovit[®] Nose Equipment

Ensembles de nez / Mundstücke / Equipaggiamento / Equipos de colocación

ø nom.	Fastener / Rivets / Niettyp / Rivetti / Remaches	Nose Equipment / Nez de pose / Mundstück / Testata / Boquilla /	Type	Part No/ref	Dimensions / Dimension / Abmessungen / Dimensioni / Dimensiones		
					B	D	E
3/32"	Briv [®] / Chobert [®] / Grovit [®]	Standard	①	07150-03003	.36	1.30	.16
		Standard cam operated	②	07170-04500	.36	1.30	
		Limited access	③	07274-01000	.22	1.07	
		Limited access cam operated	④	07177-03003	.20	1.18	
		Standard tapered	⑧	07170-03103	.36	1.30	
1/8"	Briv [®] / Chobert [®] / Grovit [®]	Standard	①	07150-03004	.41	1.18	.20
		Standard cam operated	②	07170-04600		1.18	
		Long	⑤	07150-04004		2.18	
		Long cam operated	⑥	07170-05000		2.18	
		Long curved	⑦	07150-05004		2.12	
		Standard tapered	⑧	07170-03104		1.19	
	Double Flush Chobert [®]	Standard cam operated	②	07537-03100	1.15	.23	
5/32"	Briv [®] / Chobert [®] / Grovit [®]	Standard	①	07150-03005	.48	1.30	.24
		Standard cam operated	②	07170-04700		1.30	
		Long	⑤	07150-04005		2.30	
		Long cam operated	⑥	07170-05100		2.30	
		Long curved	⑦	07150-05005		2.23	
	Chobert [®] / Grovit [®]	Standard tapered	⑧	07150-03105	.44	1.30	
3/16"	Briv [®] / Chobert [®]	Standard	①	07150-03006	.56	1.18	.33
		Standard cam operated	②	07170-04800		1.18	
		Long	⑤	07150-04006		2.30	
		Long cam operated	⑥	07170-05200		2.30	
		Long curved	⑦	07150-05006		2.21	
	Chobert [®]	Standard tapered	⑧	07150-03106	1.18		
6.0 mm	Briv [®]	Standard	①	07170-05800	.64	1.21	.52
		Standard cam operated	②	07170-05600		1.21	
		Long	⑤	07170-05900		2.19	
		Long cam operated	⑥	07170-05700		2.19	
1/4"	Chobert [®]	Standard	①	07150-03008	.64	1.18	.39
		Standard cam operated	②	07170-04900		1.18	
		Long	⑤	07150-04008		2.18	
		Long cam operated	⑥	07170-05300		2.18	

Head forming Nose Equipment / a formage de tête / kopfformend / a formatura di testa / tipo de boquilla

3/32"	Briv [®] 1)	Standard	⑨	07150-03203	.36	1.33	.24
1/8"			⑩	07170-03004	.41	1.20	.30
			⑨	07150-03204		1.22	.32
5/32"			⑩	07170-03005	.48	1.32	.41
			⑨	07150-03205		1.35	
3/16"			⑩	07170-03006	.56	1.20	.47
			⑨	07150-03206		1.24	

all dimensions in inches / en pouces / alle Maße in Zoll / in pollici / en pulgadas

1) except stainless steel and countersunk / sauf inox et tête fraisée / außer Edelstahl und Senkkopf / eccetto acciaio inox e testa svasata / excepto acero inoxidable y cabeza avellanada

⑨ maximises clench but reduces grip range by approx. .015" / obtenir le plus fort serrage possible, mais la prise maximum se trouve réduite d'environ 0,4 mm / maximierte Klammerkraft bei Verringerung des Klemmbereiches um ca. .015" / ottiene la ribaditura più alta possibile, ma la distanza massima tra i centri dei rivetti viene ridotta di circa .015" / se alcanza un máximo apriete en la fijación, pero el espesor máximo se reduce en aproximadamente .015"

⑩ increases clench without affecting grip range / Augmente le sertissage sans influencer l'epaisseur / erhöhte Klammerkraft bei gleichem Klemmbereich / aumenta la ribaditura (la presa di rivettatura) senza compromettere lo spessore / incrementa el apriete sin afectar al rango de espesores a remachar



www.avdel-global.com

© 2010 Infastech

Briv[®], Chobert[®] and Grovit[®] are trademarks of Avdel UK Limited

10.2009, page 2/2

Data shown is subject to change without prior notice as a result of continuous product development and improvement policy.
Your local Avdel representative is at your disposal should you need to confirm latest information.