

Avdelok® 2691



For installation information please refer to the tooling overview and manuals on our website www.avdel-global.com.
 Pour les conditions de pose, merci de vous référer à la description de l'outil et aux manuels disponibles sur notre site Web.
 Angaben zur Verarbeitung entnehmen Sie bitte der Geräteübersicht und den Betriebsanleitungen auf unserer Website.
 Per informazioni sull'installazione preghiamo consultare i manuali e la panoramica degli attrezzi sul nostro sito web.
 Para ver información sobre máquinas de colocación, consulte nuestra página web, apartados visión general de máquinas y manuales.

English	Français	Deutsch	Italiano	Español
Brazier head	Tête plate	Flachrundkopf	Testa tonda	Cabeza alomada
Pin: Stainless steel* natural	Tige: Inox* Brut	Bolzen: Edelstahl* Blank	Bullone: Acciaio inox * Nessuna finitura	Vástago: Acero inoxidable* Natural
Collar: Stainless steel** Zinc plated Clear trivalent passivated	Bague: Inox** Revêtement zingué Passivation claire trivalente	Schließring: Edelstahl** Verzinkt Klar chromatiert, Cr6-frei	Collare: Acciaio inox** Zincato Passivazione chiara trivalente	Collar: Acero inoxidable** Zincado Pasivado claro trivalente

*: AISI 304Cu, EN 10263-5, X3CrNiCu18-9-4 **: AISI 430, EN 10263-5 X6Cr17

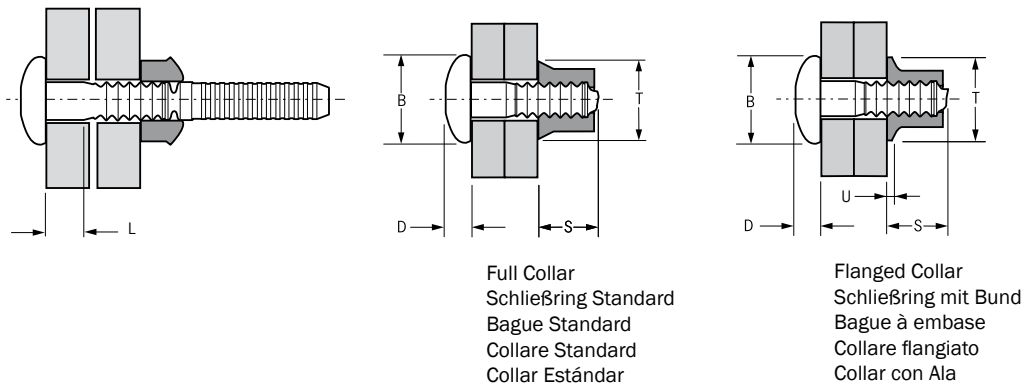

ø nom.	w. Full Collar		L nom.	B max.	D max.	Part No/ref Pin ¹⁾	Part No/ref Full Collar		Part No/ref Flanged Collar ²⁾			
	min.	max.					S max.	T max.	S max.	T max.	U ²⁾ nom.	
4.8 (3/16")	1.57	4.75	1.57	10.0	3.4	02691-00602	02605-70600	9.4	8.0	10.2	9.9	0.76
	3.18	6.35	3.18			02691-00603						
	4.75	7.92	4.75			02691-00604						
	6.35	9.53	6.35			02691-00605						
	7.92	11.10	7.92			02691-00606						
	9.53	12.70	9.53			02691-00607						
	11.10	14.27	11.10			02691-00608						
	12.70	15.88	12.70			02691-00609						
	14.27	17.45	14.27			02691-00610						
	15.88	19.05	15.88			02691-00611						
	17.45	20.62	17.45			02691-00612						
	19.05	22.23	19.05			02691-00613						
	20.62	23.80	20.62			02691-00614						
	22.23	25.40	22.23			02691-00615						
	23.80	26.97	23.80			02691-00616						
	25.40	28.58	25.40			02691-00617						
26.97	30.15	26.97	02691-00618									
28.58	31.75	28.58	02691-00619									
30.15	33.32	30.15	02691-00620									

all dimensions in mm / en millimètre / alle Maße in mm / in millimetri / en milímetros

1) & 2) see last page / voir page 3 / siehe letzte Seite / vedi pagina 3 / ver Pág. 3



www.avdel-global.com

© 2010 Infastech

Avdelok® is a trademark of Avdel UK Limited

04.2008, page 1/3

Data shown is subject to change without prior notice as a result of continuous product development and improvement policy.
 Your local Avdel representative is at your disposal should you need to confirm latest information.

Avdelok® 2691

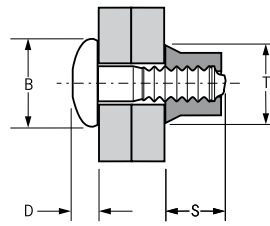
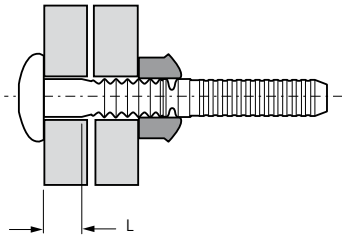

Full Collar

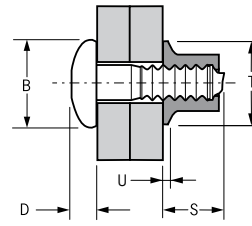

Flanged Collar

ø nom.	w. Full Collar		L nom.	B max.	D max.	Part No/ref Pin ¹⁾	Part No/ref Full Collar		Part No/ref Flanged Collar ²⁾				
	min.	max.					S max.	T max.	S max.	T max.	U ²⁾ nom.		
6.4 (1/4")	1.57	4.75	1.57	13.4	4.1	02691-00802	02605-70800	12.2	10.6	02648-70800	13.2	13.1	0.94
	3.18	6.35	3.18			02691-00803							
	4.75	7.92	4.75			02691-00804							
	6.35	9.53	6.35			02691-00805							
	7.92	11.10	7.92			02691-00806							
	9.53	12.70	9.53			02691-00807							
	11.10	14.27	11.10			02691-00808							
	12.70	15.88	12.70			02691-00809							
	14.27	17.45	14.27			02691-00810							
	15.88	19.05	15.88			02691-00811							
	17.45	20.62	17.45			02691-00812							
	19.05	22.23	19.05			02691-00813							
	20.62	23.80	20.62			02691-00814							
	22.23	25.40	22.23			02691-00815							
	23.80	26.97	23.80			02691-00816							
	26.97	30.15	26.97			02691-00818							
30.15	33.32	30.15	02691-00820										
8.0 (5/16")	3.18	9.53	3.18	16.7	5.5	02691-01004	02605-71000	15.5	13.3	N/A			
	6.35	12.70	6.35			02691-01006							
	9.53	15.88	9.53			02691-01008							
	12.70	19.05	12.70			02691-01010							
	15.88	22.23	15.88			02691-01012							
	19.05	25.40	19.05			02691-01014							
	22.23	28.58	22.23			02691-01016							
	25.40	31.75	25.40			02691-01018							
	28.58	34.93	28.58			02691-01020							
	31.75	38.10	31.75			02691-01022							
	34.93	41.28	34.93			02691-01024							
	38.10	44.45	38.10			02691-01026							
	41.28	47.63	41.28			02691-01028							
	44.45	50.80	44.45			02691-01030							
	47.63	53.98	47.63			02691-01032							

all dimensions in mm / en millimètre / alle Maße in mm / in millimetri / en milímetros

1) & 2) see last page / voir page 3 / siehe letzte Seite / vedi pagina 3 / ver Pág. 3

Avdelok® 2691

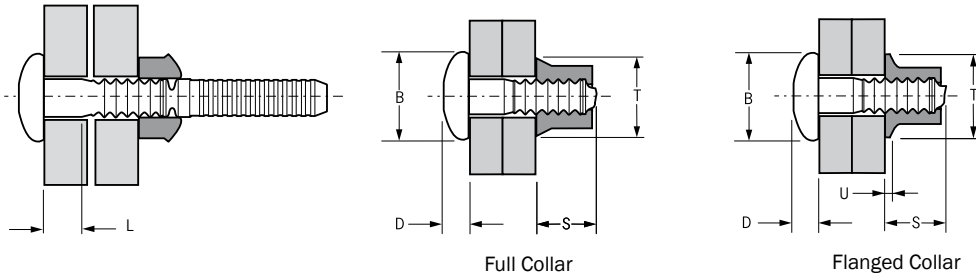

Ø nom.	w. Full Collar		L nom.	B max.	D max.	Part No/ref Pin ¹⁾	Part No/ref Full Collar		Part No/ref Flanged Collar ²⁾		
	min.	max.					S max.	T max.	S max.	T max.	U ²⁾ nom.
9.6 (3/8")	3.18	9.53	3.18	20.0	6.7	02691-01204	02605-71200	18.6	15.5	N/A	
	6.35	12.70	6.35			02691-01206					
	9.53	15.88	9.53			02691-01208					
	12.70	19.05	12.70			02691-01210					
	15.88	22.23	15.88			02691-01212					
	19.05	25.40	19.05			02691-01214					
	22.23	28.58	22.23			02691-01216					
	25.40	31.75	25.40			02691-01218					
	28.58	34.93	28.58			02691-01220					
	31.75	38.10	31.75			02691-01222					
	34.93	41.28	34.93			02691-01224					
	38.10	44.45	38.10			02691-01226					
	41.28	47.63	41.28			02691-01228					
	44.45	50.80	44.45			02691-01230					
	47.63	53.98	47.63			02691-01232					

all dimensions in mm / en millimètre / alle Maße in mm / in millimetri / en milímetros

1) Different grip range pins with different numbers of grooves are available

Tiges avec autres plages de serrage et différent nombre de cannelures sont disponible

Bolzen mit anderem Klemmbereich und anderer Anzahl von Rillen sind verfügbar

Sono disponibili bulloni con spessori serrabili differenti con diverso numero di scanalature

Disponibles pernos con diferente número de anillos según el espesor a remachar

2) Flanged collars are used in applications where the hole on the collar side of the application is oversize or is slotted for alignment purposes. To determine what length of pin is required, add dimension U to the thickness of material being fastened.

Avec une bague à embase, la plage de serrage est diminuée de la valeur de la cote U.

Schließringe mit Bund werden in Anwendungen benötigt, wo das Bohrloch auf der Schließringseite übergroß oder länglich ist. Um den richtigen Bolzen zu bestimmen, addieren Sie das Maß U zu der zu verbindenden Materialstärke hinzu.

Utilizzando i collari flangiati la dimensione „U“ deve essere aggiunta allo spessore da serrare per determinare il tipo di bullone adatto.

Utilizar collar con ala cuando en la aplicación el taladro está sobredimensionado o es ranurado. Para calcular la referencia de perno necesaria añadir la cota U al espesor de la aplicación.

Ø nom.	← → kN ³⁾	⬇ ⬆ kN ³⁾
4.8 (3/16")	7.79	9.26
6.4 (1/4")	14.55	17.71
8.0 (5/16")	22.24	29.80
9.6 (3/8")	31.58	37.81

3) These figures represent minimum fastener shear and tensile strength values with the use of a full collar.

Cette valeurs représentent minimum résistances au cisaillement et à la traction avec l'usage d'une bague standard.

Diese Werte repräsentieren Minimum Scher- und Zugfestigkeiten der Verbindung unter Verwendung von Standard-Schließringen.

I dati indicati in tabella sono minimi e si riferiscono a bulloni installati con collari Standard.

La figura representa los valores mínimos de resistencia a la cortadura y tracción cuando se utiliza collar estándar.