

Hydro-pneumatic Handtool for Lockbolts

722 Model

Features

- Robust and durable construction
- Cast aluminium tool body
- Designed for heavy duty use over long periods of time
- Wide choice of different nose assemblies to suit the access restrictions of the application

Benefits

- Extremely durable lockbolt tool
- High reliability
- Can be fitted with a collar cropper to remove installed Avdelok® lockbolts

Specifications

Weight (without nose equipm.)	5.0 kg (11 lbs)
Pull force @ 5.5 bar	26.7 kN (6000lbf)
Stroke min.	19 mm (0.75ins)
Cycle time	3.0 sec
Air supply pressure	5.4 – 8.5 bar
Free air volume @ 5,1 bar	14.6 litres
Noise level	72 dB(A)
Vibration	< 2.5m/s ²

Placing capability

Avdelok® lockbolts \varnothing 6.4 mm ($\frac{1}{4}$ ") to 9.6 mm ($\frac{3}{8}$ ") and Avbolt® structural blind fasteners \varnothing 4.8 mm ($\frac{3}{16}$ ") to 8.0 mm ($\frac{5}{16}$ ").

For detailed information on placing capability and nose equipment please refer to the tool manual on our website www.avdel-global.com or contact your local Avdel representative.



Dimensions (mm/inch)

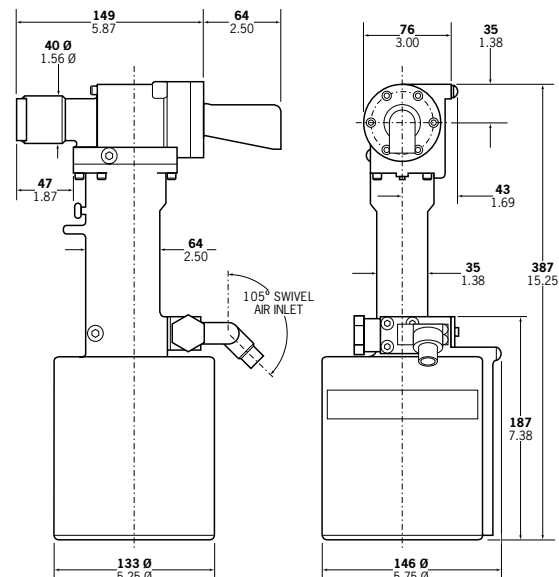

Avdel USA LLC
614 NC Highway 200 South
Stanfield, North Carolina 28163
Tel. +1 704 888-7100 · Fax -0258
infoAvdel-USA@infastech.com

www.avdel-global.com

Avdel Canada Limited
1030 Lorimar Drive
Mississauga, Ontario L5S 1R8
Tel. +1 905 364-0664 · Fax -0678
infoAvdel-Canada@infastech.com

© 2010 Infastech

Avbolt® and Avdelok® are trademarks of Avdel UK Limited.

Data shown is subject to change without prior notice as a result of continuous product development and improvement policy.
Your local Avdel representative is at your disposal should you need to confirm latest information.

03.2010