

Hydro Pneumatic Tool for Threaded Inserts

74200 Model

Features

- Heavy duty plastic body and long-life components
- Lightweight and ergonomically designed
- Latest 'spin-pull' technology
- One-step trigger
- Can be suspended or hand-held

Benefits

- Ideal for demanding production environments
- Quick and simple operation
- Reduces operator fatigue
- Increased productivity
- Places a wide range of threaded inserts
- Ensures accurate and secure thread installation

Specifications

Weight	2.2 kg (4.9 lbs)
Pull Force	19.1 kN (4,300 lbf)
Stroke	7 mm (0.276 in)
Cycle Time	2.5 sec
Air Supply Pressure	5 - 7 bar
Free air volume	8 litres
Noise level	75 dB(A)
Vibration	<2.5m/s ²

Placing capability

Avdel threaded inserts up to M12.
For detailed information on placing capability and nose equipment please refer to the tool manual on our website www.avdel-global.com or contact your local Avdel representative.

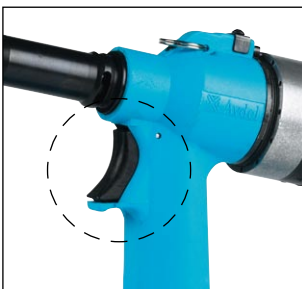

One-step trigger reduces cycle time to a minimum



Dimensions (mm/inch)

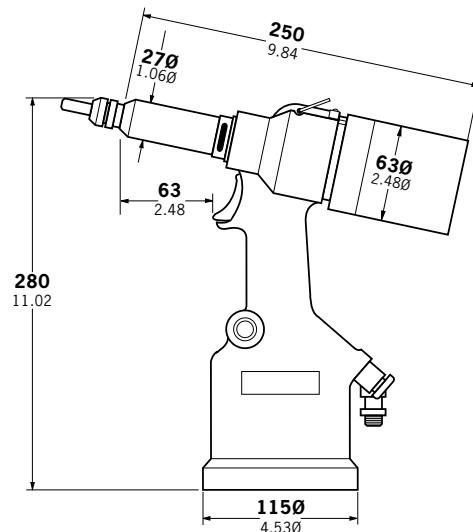

Avdel USA LLC
614 NC Highway 200 South
Stanfield, North Carolina 28163
Tel. +1 704 888-7100 · Fax -0258
infoAvdel-USA@infastech.com

www.avdel-global.com

Avdel Canada Limited
1030 Lorimar Drive
Mississauga, Ontario L5S 1R8
Tel. +1 905 364-0664 · Fax -0678
infoAvdel-Canada@infastech.com

© 2010 Infastech

04b.2007