

# Hydro Pneumatic Tool for Versa-Nut® Threaded Inserts

## 74405 Series

### Features

- Tool specific for Versa-Nut® inserts
- Split tool
- Lightweight placing head

### Benefits

- High placement speed
- Lightweight tool
- Robust tool
- Ergonomic
- Ease of maintenance

### Specifications

|   |                      |
|---|----------------------|
| Head Weight<br>(without nose equipment) | 2.0 kg (4.4 lbs)     |
| Pull Force @ 5.5 bar                    | 13.84 kN (3111 lbf)  |
| Stroke (maximum)                        | 16 mm (0.63 in)      |
| Air Supply Pressure                     | 5 – 7 bar            |
| Free air volume @ 5.5 bar               | 15 litres            |
| Noise level                             | <75 dB(A)            |
| Vibration                               | <2.5m/s <sup>2</sup> |

### Placing capability

Avdel Versa-Nut® threaded inserts M4 to M10.  
For detailed information on placing capability and nose equipment please refer to the tool manual on our website [www.avdel-global.com](http://www.avdel-global.com) or contact your local Avdel representative.



### Dimensions (mm)

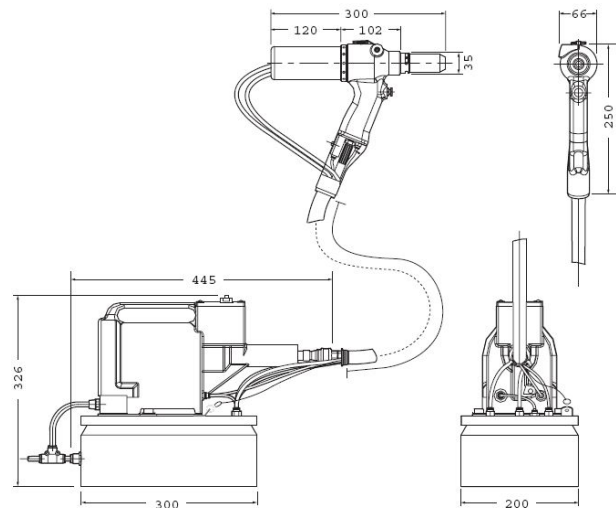

Avdel USA LLC  
614 NC Highway 200 South  
Stanfield, North Carolina 28163  
Tel. +1 704 888-7100 · Fax -0258  
[infoAvdel-USA@infastech.com](mailto:infoAvdel-USA@infastech.com)

[www.avdel-global.com](http://www.avdel-global.com)

Avdel Canada Limited  
1030 Lorimar Drive  
Mississauga, Ontario L5S 1R8  
Tel. +1 905 364-0664 · Fax -0678  
[infoAvdel-Canada@infastech.com](mailto:infoAvdel-Canada@infastech.com)

© 2010 Infastech

Versa-Nut® is a trademark of Avdel UK Limited

Data shown is subject to change without prior notice as a result of continuous product development and improvement policy.  
Your local Avdel representative is at your disposal should you need to confirm latest information.

02a.2008