

Genesis® nG4 Hydro Pneumatic Tool

71234 series with fixed stem collector bottle

Features

- Lightweight tool
- Toughened plastic body and heavy duty rubber base
- Vacuum air supply cut-off on trigger
- Enhanced tool life
- Soft touch rubber grip on handle
- Integral cycle counter

Benefits

- Reduces operator fatigue
- High placement speed
- Robust tool
- Minimized air consumption
- Places a wide range of lockbolts & breakstem fasteners
- Ergonomic

Specifications

Weight (min. with equip.)	2.3 kg (5.1 lbs)
Pull force @ 5.5 bar	18.68 kN (4200 lbf)
Stroke (min.)	17 mm (0.67 in)
Cycle time (approx.)	1.2 sec
Air supply pressure	5-7 bar (80-100 psi)
Free air volume @ 5.5 bar	4.3 litres
Noise level	<75 dB(A)
Vibration	<2.5m/s ²

Placing Capability

Up to 6.4mm (1/4") breakstem rivets produced by Avdel except Monobolt® and Interlock® structural rivets.

Can also place:

Avseal® II sealing plugs up to 12 mm

Avtainer® lockbolts 10.0 mm (3/8")

Avdelok® and Maxlok® lockbolts 4.8 mm (3/16") and 6.4 mm (1/4")

Hemlok® structural rivets 6.4 mm (1/4")

Avibulb® XT and Avinox® XT structural rivets

For detailed information on placing capability and nose equipment please refer to the tool manual on our website www.avdel-global.com or contact your local Avdel representative.



Dimensions (mm)

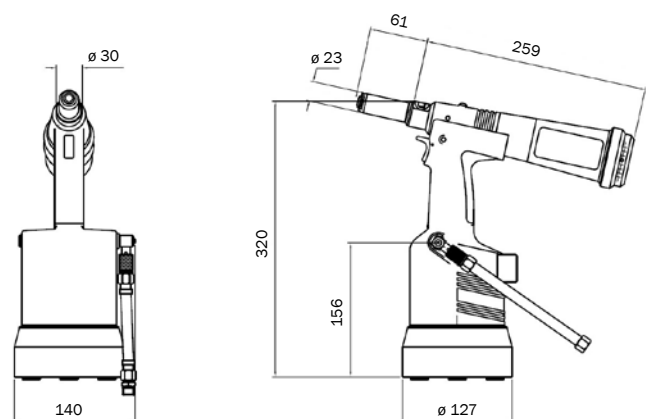

www.avdel-global.com

Avdel UK Limited
Pacific House, 2 Swiftfields
Welwyn Garden City, Hertfordshire AL7 1LY
Tel. +44 (0)1707 292-000 · Fax -199
enquiries@infastech.com

© 2010 Infastech

Avdel Patent Protected. Avdelok®, Avseal®, Avibulb®, Avinox®, Avtainer®, Hemlok®, Interlock®, Genesis®, Maxlok®, Monobolt® are trademarks of Avdel UK Limited. 03a.2010

Data shown is subject to change without prior notice as a result of continuous product development and improvement policy.
Your local Avdel representative is at your disposal should you need to confirm latest information.